

DIVATOR MKIII REGULATOR

- ❶ Dual first stage regulators integrated in one unit
- ❷ Safe transition into reserve air mode with "Pull for air"-solution
- ❸ Primary regulator can be isolated by "Push" maneuver
- ❹ DP1 high pressure surface supply inlet port
- ❺ Outlets for connection of BC, dry suit and Octopus



DIVATOR MKIII REGULATOR

REFERS TO PRODUCT(-S) WITH PART NO.(-S)
MKIII Regulator 30 026

The DIVATOR MKIII regulator has an extremely high flow capacity. The design ensures that the intermediate pressure leading to the breathing valve is stable and is not affected by pressure variations in the air supply or the depth of the dive.

The DIVATOR MKIII includes outlets that provide convenient air supply connections for buoyancy compensating jacket, dry suit and DIVATOR Octopus breathing valve.

Dual first stage regulators integrated in one unit gives the diver great advantages if problem arises during the dive by giving the diver several options to handle the situation.

The MKIII regulator is constructed to give the diver at least two breathing sources, two inflation sources and two ways to isolate air loss.

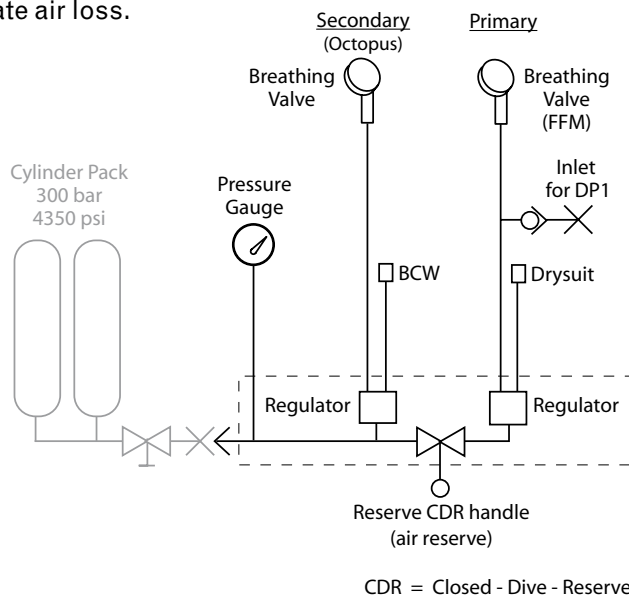

STANDARDS

Designed and tested in accordance with EN 250

APPROVALS

CE 89/686/EEC

PERFORMANCE

Meet performance requirements of EN 250.
Designed for use in cold waters.

Designed so that the primary regulator and/or the breathing valve can be isolated in the event of freezing or other malfunction.

Reserve valve handle gives the diver a warning when the air pressure becomes low.

- Fully functional in (air) temperature range of: -30 to +70°C (-22 to +158°F)
- Medium press. range: 5-11 bar (72-159 psi)
- Safety valve (built in feature) opening pressure: 12-20 bar (174-290 psi)

CONNECTIONS

- Supplied with Octopus hose and breathing valve.
- Two extra outlets with 3/8" thread.
- DP1 high pressure surface supply hose connection.

AVAILABLE VARIANTS

- Regulator with BC & dry suit hose (0.75 m / 2.5 ft) 30 026-01
- Regulator, plugged (without hoses) 30 026-02
- Regulator with BC & dry suit hose (1 m / 3.3 ft) 30 026-03

INTERSPIRO

www.interspiro.com

CENTRAL EUROPE

AUSTRIA

INTERSPIRO GesmbH www.interspiro.de
Feldbacher Str. 3 A-8200 GLEISDORF AUSTRIA
TEL +43 (0)311 236 133 FAX +43 (0)311 236 133 22 E-MAIL info@interspiro.de

GERMANY

INTERSPIRO GmbH www.interspiro.de
Postfach 1220 D-76691 FORST/BADEN GERMANY
TEL +49 (0)7251 8030 FAX +49 (0)7251 2298 E-MAIL info@interspiro.de

SWITZERLAND

INTERSPIRO AG www.interspiro.de
Güterstraße 47 CH-4133 PRATTELN SWITZERLAND
TEL +41 61 827 99 77 FAX +41 61 827 99 70 E-MAIL info@interspiro.ch

THE NETHERLANDS & BELGIUM

INTERSPIRO BV www.interspiro.nl
Televisieweg 113 NL-1322 BD ALMERE NETHERLANDS
TEL +31 (0)36 5363103 FAX +31 (0)36 5384809 E-MAIL infobv@interspiro.com

NORTH & SOUTH AMERICA

INTERSPIRO Inc. www.interspiro-us.com
10225 82nd Avenue PLEASANT PRAIRIE WI 53158-5801 USA
TEL +1 262 947 9901 FAX +1 262 947 9902 E-MAIL sales@interspiro-us.com

UNITED KINGDOM & IRELAND

INTERSPIRO Ltd. www.interspiro.com
7 Hawksworth Road Central Park TELFORD Shropshire TF2 9TU UNITED KINGDOM
TEL +44 (0)1952 200 190 FAX +44 (0)1952 299 805 E-MAIL infouk@interspiro.com

SCANDINAVIA, ASIA/PACIFIC & MIDDLE EAST

SWEDEN

NORDIC & EXPORT SALES DIVISION www.interspiro.com
Box 10060 S-181 10 LIDINGÖ SWEDEN
TEL +46 8 636 51 00 FAX +46 8 636 51 99 E-MAIL info@interspiro.com

MALAYSIA

NORDIC & EXPORT SALES DIVISION www.interspiro.com
305 & 305A Lorong Perak Taman Melawati 53100 KUALA LUMPUR MALAYSIA
TEL +60 3 4105 8122 FAX +60 3 4105 3122 E-MAIL asiapacific@interspiro.com